

A/22 L - A/32 L



la Minerva



A/22 L - A/32 L

TRITACARNE DA BANCO 22-32 IN ACCIAIO INOX. Tritacarne per medie e alte produzioni, macchine robuste, affidabili, compatte, facili da pulire. Per macellerie, super-mercati, laboratori carni, ristorazione.

- Costruzione compatta ed elegante in acciaio inox AISI 304
 - Tramoggia estraibile in acciaio inox AISI 304
 - Bocca in acciaio inox AISI 304, facilmente smontabile per la pulizia. Conforme alle normative in vigore sui materiali a contatto con gli alimenti. Disponibile nella versione **Enterprise**: 1 piastra ed 1 coltello in acciaio inox, autoaffilanti
 - Dispositivo di inversione di marcia
 - Pulizia semplice e veloce
- A richiesta:**
- Voltaggi speciali

STAINLESS STEEL TABLE TOP MEAT MINCER 22-32. Meat mincers for medium and large production: strong reliable, compact, easy to clean. Machines suitable for butcher shops, supermarkets, meat processing centres, catering industries.

- Styled and compact construction in stainless steel AISI 304
 - Removable AISI 304 stainless steel feed pan
 - AISI 304 stainless steel head, readily disassembled for easy cleaning. In compliance with standards in force regarding foodstuff. Available in the **Enterprise** self sharpening plate and knife in stainless steel
 - Reverse device
 - Easy and fast cleaning
- Available upon request**
- Special voltages

HACHOIR A VIANDE EN ACIER INOX 22-32 DU COMPTOIR. Hachoirs pour moyennes et hautes productions. Machines robustes, fiables, compactes, d'entretien facile, conçues pour boucheries, supermarchés, centres de transformation des viandes, restauration.

- Construction solide et de forme élégante en acier inox AISI 304
 - Trémie extractible en acier inox AISI 304
 - Bouche en acier inox AISI 304 rapidement démontable pour faciliter le nettoyage. Conforme aux normes en vigueur en matière de parties qui soient en contact avec les aliments. Version **Simple Coupe**: plaque et couteau en acier inox autoaffilants
 - Dispositif d'inversion de marche
 - Nettoyage simple et rapide
- Sur demande:**
- Tensions particulières

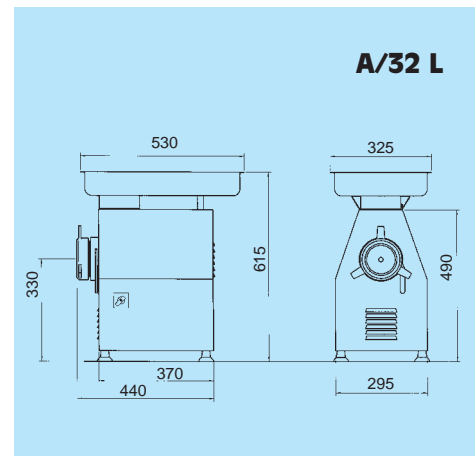
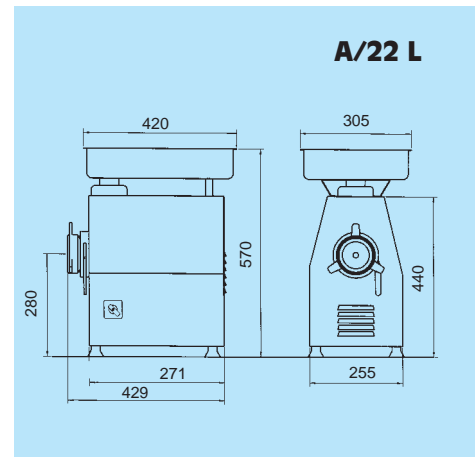

		A/22 L	A/32 L
Bocca - Head - Corps		22	32
Produzione - Production - Production	kg/h (kg/min)	300 (5)	500 (8,3)
Potenza - Power - Puissance	kW (HP)	1,1 (1,5)	2,2 (3)
Peso netto TF/MF - Net weight TPH/SPH - Poids net TPH/MN	Kg	33 (34)	50 (51)

IL VOSTRO CONCESSIONARIO - YOUR DISTRIBUTOR - VOTRE REVENDEUR



ÜBERREICHT DURCH - VUESTRO CONCESIONARIO

la Minerva
FOOD SERVICE EQUIPMENT

Via Massarenti, 221/5 - 40138 Bologna (Italia)
Tel. +39 051 530.174 - Fax +39 051 535.327
Internet: <http://www.laminerva.it>
e-mail: laminerva@laminerva.it

